

Stealthbox®

INSTALLATION GUIDE
for the
SB-POL-RNGR/SYS
SKU#94425
2004-2008



Thank you for choosing a JL Audio Stealthbox® for your all-terrain vehicle. With proper installation, your new vehicle-specific enclosed speaker system will deliver years of listening pleasure.

We strongly recommend that you have your new Stealthbox® installed by your authorized JL Audio dealer. The installation professionals employed by your dealer have the necessary tools and experience to disassemble and reassemble your vehicle properly. If you prefer to perform your own installation, please read this installation guide completely before beginning the process.

JL AUDIO®
Ahead of the Curve™

! IMPORTANT

If you choose to perform the installation yourself, it is absolutely vital that the enclosures be properly mounted to the vehicle according to these instructions. Failure to mount the enclosure properly presents two problems:

- 1) The sub-bass performance will suffer due to the movement of the enclosure caused by the force exerted by the woofer(s).
- 2) A loose enclosure presents a serious safety hazard in the event of a collision or sudden deceleration.

INSTALLATION DIFFICULTY:

3 OUT OF 5

ESTIMATED TIME:
2-3 HOURS



STEP 1

Many of the following steps will be repeated on both sides of the vehicle.

Remove the five screws that secure each of the kick panels. (see circled areas, there are also two inside)



STEP 2

The kick panels can be removed by pulling up at the bottom and towards the rear, hinging the panel backwards and out.



STEP 3

Before test fitting the subwoofer enclosure, make yourself familiar with the location of the threaded insert on the top of the enclosure.

From the passengers side, test fit the subwoofer enclosure into the dash with the raised part of the enclosure going up and, behind the dash cross-dash bar as shown.

Now is a good time to test the performance of the Subwoofer.



STEP 4

Looking from under the hood take note of the location of the relay that is screwed to the cross channel. Inside that channel on the bottom there is a hole that should line up with the threaded insert in the top of the Stealthbox®, this hole needs to be enlarged (see DETAILS below)

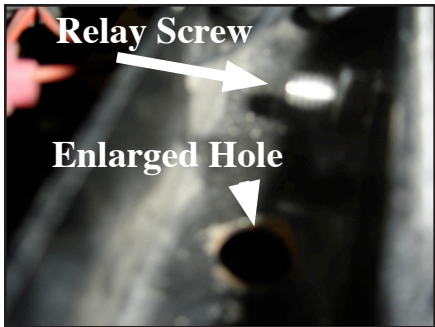

DETAIL

This DETAIL at left, shows a view looking down into the cross-dash channel, note the relation of the Relay holding screw and the enlarged hole. Make sure that the threaded insert lines up with the correct hole so that you will only need to drill one hole. There will be a 3/8-16x 1 1/2" Hex Head Bolt, Split Lock Washer and, 3/8x 1 1/4" Fender Washer inserted into this channel and, through the hole then through the 1/2" Aluminum Spacer and threaded into the top of the Stealthbox® (see DETAIL illustration at far right).



DETAIL

Enlarge the hole in the cross-dash channel by drilling from below (there is no access from above) again, ensure that you will be enlarging the correct hole in the channel!

CAUTION

Before drilling, always make sure that you are not going to be drilling into any gas lines, brake lines, transmission lines, electrical wiring, exhaust systems or anything else that might cause a reduction in your weekly pay. Always wear eye protection when drilling.



STEP 5

Set the Square U-Bolt in place over the bottom cross-dash bar, slide it towards the drivers side of the vehicle.

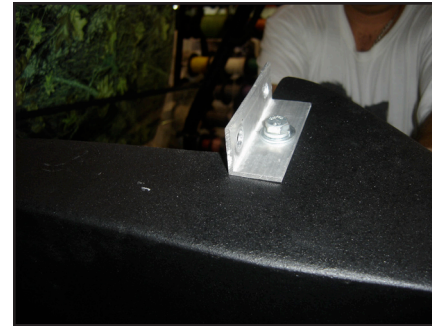

STEP 6

Install the included Custom Aluminum Bracket on the drivers side of the subwoofer enclosure as shown using the supplied 3/8-16x 1" Hex Head Bolt, Split Lock Washer and Flat Washer, these fasteners should be snug but, do not need to be tight at this time. Install a length of wire that will reach from the mounted enclosure to the amplifier location.

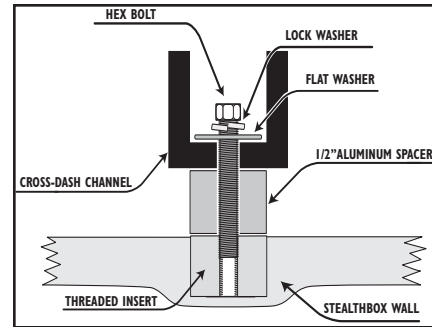

DETAIL

This is how the hardware should be arranged in the channel then, threaded into the top of the enclosure. (as mentioned at far left)

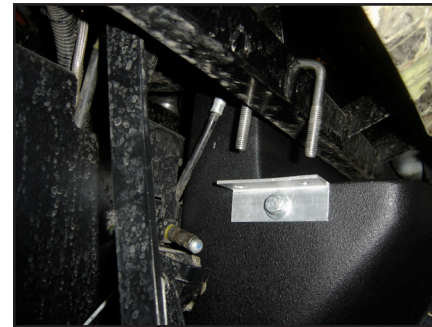

STEP 7

Sliding the enclosure back into place, make sure that the wire is not pinched or damaged and align the top threaded insert with the hole enlarged in **STEP 4**. Start the hardware as mentioned before into the threaded insert. Also align the Custom Aluminum Bracket and the Square U-Bolt and start a Flat Washer, Split Lock Washer and Hex Nut on each leg of the Square U-Bolt.

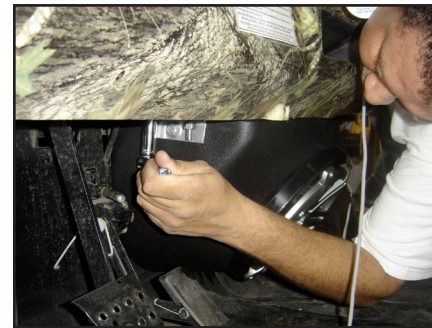

STEP 8

Once all of the hardware is started, tighten all of the fasteners, rotating from each nut to another like you were changing a tire.



STEP 9

Install a piece of the included Self Adhesive Gasket Material along the outer edge of each frame rail where the OEM kick panels had been attached.



STEP 10

Run the wire from each of the kick panels to the amplifier location, slide the kick panels into place using the opposite method from what was done to remove the OEM kick panels. Position the housings so that the screw holes along the frame rail line up with the holes in the enclosure. Using the OEM hardware, attach each enclosure to the frame rails of the vehicle.

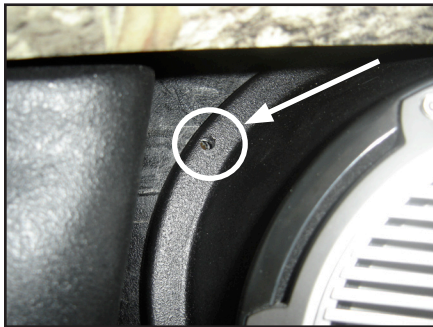

STEP 11

Along the inner edge of each speaker housing there are two screw holes that will need to have pilot holes drilled and then have the supplied 1/4x 1" Button Head Allen Bolts installed through the flanges and the floor, under the floor there should be a fender washer against the floor and, a 1/4-20 Locknut installed to secure the speaker housings to the floor of the vehicle.



STEP 12

CONGRATULATIONS!

You have completed the installation for this model!

Enjoy your new Stealthbox®! Go out in the woods and get dirty!

Please refer to the Power Recommendation section for an amplifier recommendation and basic set-up help.

INCLUDED HARDWARE

- 1) Custom Aluminum Bracket
- 1) 3/8-16x 1" Hex Head Bolt
- 4) 3/8 Split Locking Washer
- 1) Square U-Bolt (with washers and, nuts)
- 4) 1/4-20 Lock Nut
- 1) 3/8-16x 1 1/2" Hex Head Bolt
- 1) 3/8 x 1 1/4" Fender Washer
- 1) 3/8 Flat Washer
- 4) 1/4x 1" Button Head Allen Bolt
- 1) 1/2x 1" Custom Aluminum Spacer

SPECIFICATIONS

Subwoofer Enclosure Type: Acoustic Suspension (sealed)

Driver Type: M10W5

Nominal Impedance: 4 Ohms

Continuous Power Handling: 250 Watts (RMS)

Kickpanel Enclosure Type: Infinite Baffle

Driver Type: M770-CCX

Nominal Impedance: 4 Ohms

Continuous Power Handling: 100 Watts (RMS)

POWER RECOMMENDATION

JL Audio recommends using a high quality amplifier such as the JL Audio M4500. The diagram below shows the recommended crossover and input settings for the M4500 when being used to power your Stealthbox®.

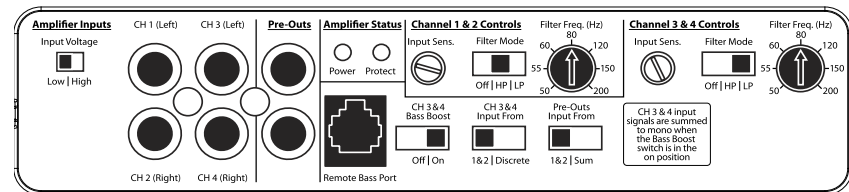

The JL Audio M4500 is a very versatile audio component. Please consult the owner's manual for even more detailed information about installing and tuning this amplifier.

JL AUDIO®

Ahead of the Curve™

(954) 443-1100

www.jlaudio.com

All specifications are subject to change without notice. "JL Audio" and the JL Audio logo, "Stealthbox" and the Stealthbox logo are registered trademarks of JL Audio, Inc. "Ahead of the Curve" and its respective logo is a trademark of JL Audio, Inc.
 JLA-SKU#011278 ©10-15-2008 • Printed in USA • ©2008 JL Audio, Inc. • U.S. PATENTS: #5,734,734 #5,949,898 #6,118,884 #6,229,902 #6,243,479 #6,294,959 #6,501,844 #6,496,590 #6,441,685 #5,687,247 #6,219,431 #6,625,292 #D472,891 #D480,709 Other U.S. & Foreign patents pending. For more detailed information please visit us online at www.jlaudio.com.

